



Atrium News!!!

November 2001

Atrium Professional Series Doors



Our professional series doors feature aluminum clad pre-painted exteriors that provide durability and strength against the elements. Interiors are unfinished and ready for the paint of your choosing.

Doors are pre-bored for your choice of lock and dead bolt.

Anodized aluminum sills with integral weep system and thermal breaks are also standard. Thermal breaks reduce conductive heat loss.

One lite is standard. Removable interior wood grilles, internal aluminum bars or Atrium Classic Lite (ACL) provides a true divided appearance.

Exceptional Performance

On time shipments: We shipped 92.7% of our orders on time during the month of September.

Order Accuracy: We shipped 99.3% of our orders correctly during the month of September.

Damaged Shipments: During the month of September, 99.2% of our shipments were reported as being received in good condition.

Phone activity: During the month of September, our Customer Service Team received 4192 calls. The average hold time was less than one minute. The longest hold time was 5.22 minutes.

Contact Information

Phone Number 800-935-2000. Dial 4 to speak with Customer Service
Customer Service is available 8:00 to 6:00 (Central Time) Monday thru Friday

Fax Number 214-637-6724

Customer Service

Manager: David Tjaden
Ext 1213

Technical Services

Kris Nelson Ext 1147

Shipping Address:
Atrium Door Co.

1001 Ed Rutherford Road
Greenville, TX 75402

In case of an Emergency

General Manager: Randy Rice
Ext. 1238

David Tjaden 903-456-4103

David Bryant 863-324-1606

If you have been holding for an excessive amount of time, contact Atrium's receptionist at extension 1212

Features and Benefits

Professional Series

FRAME

Extruded aluminum clad, pre-painted exterior provides durability and strength against the elements or unfinished for your choice of color. Interior is unfinished and ready for the paint of your choosing.

PANEL

Extruded aluminum clad exterior available in white, earthtone, sandstone, and green; unfinished interior.

GLASS

Tempered 3/4" insulated double sealed for long lasting performance. Tempered LoE2, Bronze, Gray, or Obscure are also available.

HARDWARE

Doors are pre-bored for a lock and dead bolt. Select from many manufacturers styles and finishes.

SILL

Extruded aluminum anodized thermally broken sill reduces conductive heat loss, designed to keep weather out.

COLORS

Available in white, earthtone, sandstone, or green.

LITE PATTERNS

Removable interior wood grilles, internal aluminum bars or Atrium Classic Lite (ACL) provide a true divided appearance. One lite is standard.

TRANSOMS

Available in rectangle or eyebrow units to top off any door.

EXTENSION JAMBS

Extension kits for 6 9/16" wall.

Design Series

FRAME

Extruded aluminum clad, pre-painted exterior provides durability and strength against the elements and is standard on all Design Series Doors. Interior is clear unfinished pine and ready for paint or stain

PANEL

Extruded aluminum clad exterior in white, earthtone, or sandstone is standard on all Design Series Doors; clear unfinished pine interior.

GLASS

3/4" High Performance Argon filled LoE2 tempered glass insulated, double sealed for long lasting performance. Bronze, Gray, or Obscure are also available.

HARDWARE

The Atrium Door features a polished brass 3 point multi-point locking system.

The French Classic features a polished 5 point multi-point locking system which uses a dual lock 3 point on the primary panel and 2 point on the second panel.

SILL

Extruded aluminum anodized thermally broken sill reduces conductive heat loss, designed to keep weather out.

COLORS

Available in white, earthtone, sandstone, or green.

LITE PATTERNS

Removable interior wood grilles, internal aluminum bars or Atrium Classic Lites (ACL) provide a true divided appearance. One lite is standard.

TRANSOMS

Available in rectangle or eyebrow units to top off any door

EXTENSION JAMBS

Extension kits for 6 9/16" wall.

Swing Door

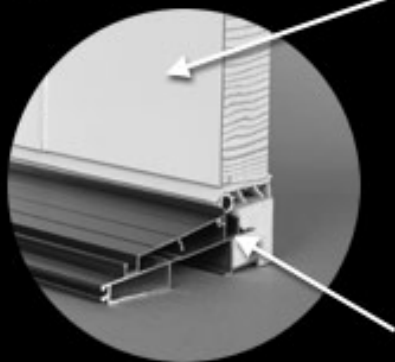

Extruded aluminum clad exterior

Unique self-draining thermally efficient sill system

Sliding Door

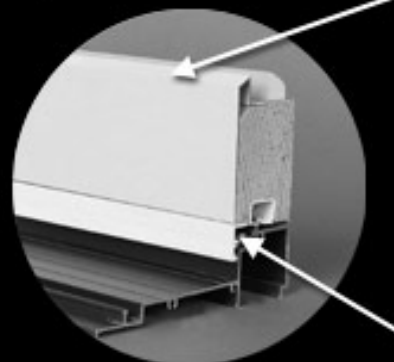

Extruded aluminum clad exterior

High rise thermally broken sill keeps weather out